

TRD

FOUR POST

4-POST PARKING LIFT

TRD 4-POST PARKING LIFTS ARE THE PROFESSIONAL DESIGN FOUR POST LIFTS FOR STORAGE AND GENERAL SERVICE.

THESE 4-POST PORTABLE LIFTS ARE DESIGNED WITH INTERNAL SAFETY LOCKS SYSTEM AND SUPERIOR QUALITY THAN MOST OF THE STORAGE 4-POST LIFTS IN THE WORLD.



TP-034A TPH-034A
TP-534A TPH-044A

PARKING LIFT

SPECIFICATIONS PRODUCTS

MODEL		TP-034A	TPH-034A	TP-534A	TPH-044A
Lifting capacity		3000kg	3000kg	3500kg	4000kg
Lifting time		31S	37S	38S	67S
Overall Length(In.Ramp)	A	4712mm	5000mm	5257mm	5957mm
Overall Length(No.Ramp)	B	3862mm	4150mm	4400mm	5100mm
Overall Width	C	2409mm	2409mm	2784mm	3206mm
Width Between Posts	D	2167mm	2167mm	2438mm	2860mm
Max. Lifting height	E	1872mm	2202mm	1872mm	2227mm
Overall height	F	2105mm	2455mm	2105mm	2455mm
Minimum height	G	135mm	135mm	155mm	155mm
Max. Underneath Height	H	1772mm	2102mm	1752mm	2107mm
Drive-Thru Clearance	I	1956mm	1956mm	2074mm	2496mm
Width Between Runways	J	940mm	940mm	940mm	1077mm
Outside Edge of Runways	K	1890mm	1890mm	1890mm	2093mm
Motor		220V, 50Hz, 3.0HP			
Gross Weight		700kg	763kg	747kg	904kg

FEATURES PRODUCTS

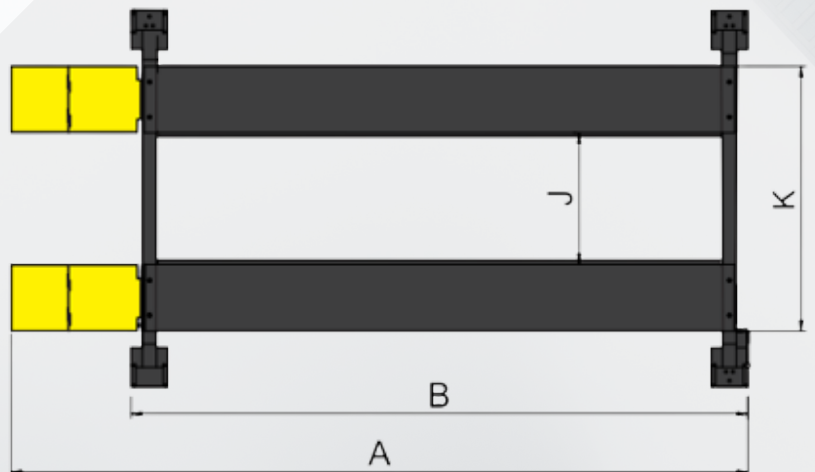
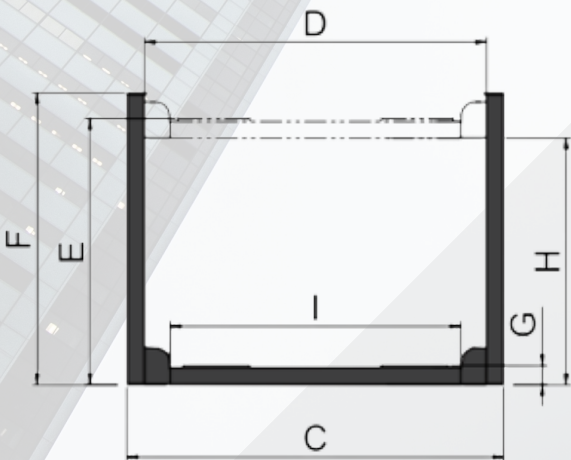

PARKING LIFT

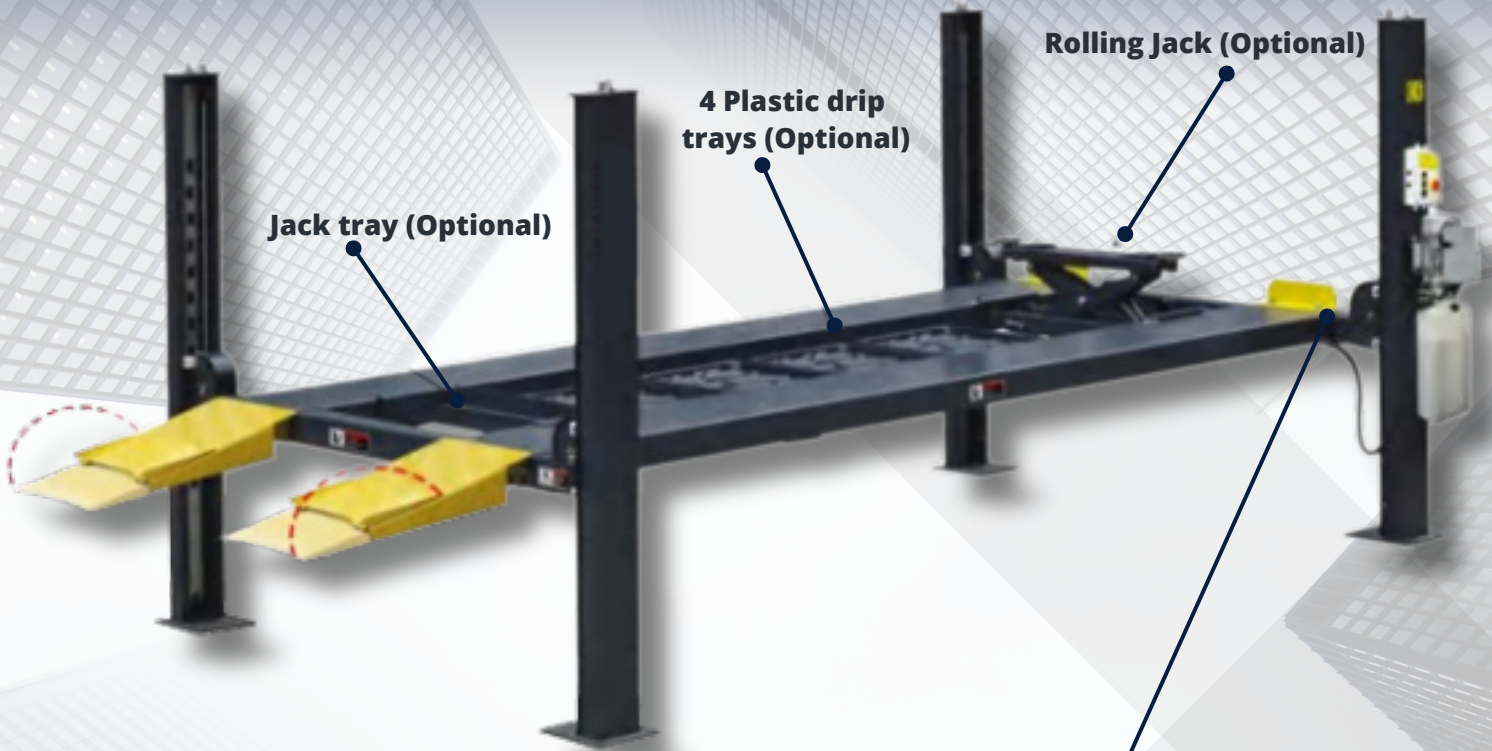

Jack tray (Optional)

4 Plastic drip trays (Optional)

Rolling Jack (Optional)

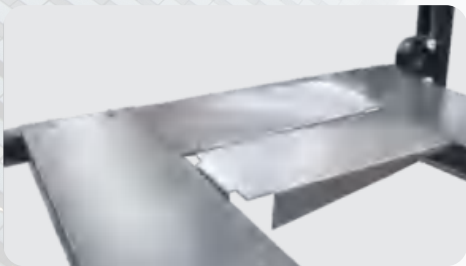

Optional aluminum alloy drive-in ramps. Weight for one set, which includes 2 pieces, is only 18kg. Kits No.: T30804

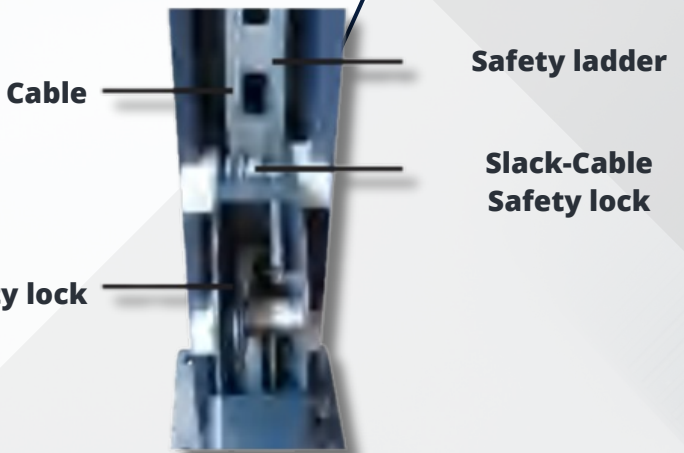

Cable

Safety ladder

Slack-Cable Safety lock

Primary safety lock

Commercial double safety locks provide additional safety.



Optional J5H sliding jack with hand pump for TP-034A, TPH-034A, TP-534A, 1.5" and 2.5" extension adaptors included. Capacity: 2200kg.



Rolling jack J6H for TPH-044A
The Rolling Jack J6H is come with hand pump and 1.5" & 2.5" extension adaptors. This is the same rolling jack use for our general service four post lifts. Capacity:2800kg



Optional Motor protective cover (with emergency stop switch) Kit No.:T01804

FOUR-POST

4-POST PARKING LIFT

TRD FOUR-POST PARKING LIFTS ARE DESIGNED WITH COMMERCIAL PULLEY, AERO CABLE, DOUBLE-COLUMNS, DOUBLE SAFETY LOCKS, ETC. IT IS A REALLY COMMERCIAL PRODUCT WITH SUPERIOR QUALITY THAN MOST OF THE PARKING LIFTS IN THE WORLD.

FEATURES

- TRD exclusive hidden safety locks and manual single-point release device allows operators to unlock the safety locks from one column. Double-shaped columns help increase the columns' strength.
- FOUR POST
- 4 Plastic drip trays (Optional)
- Jack tray (Optional)
- Rolling Jack (Optional)
- Skid proof diamond platform provides traction for the tires to stay put. Flexible design: The power side column can be installed at any corner. Portable design, can easily be moved by using the caster kits. Warranty:
5-Year: Steel structured components.
3-Year: Hydraulic parts or components.
2-Year: Electrical parts

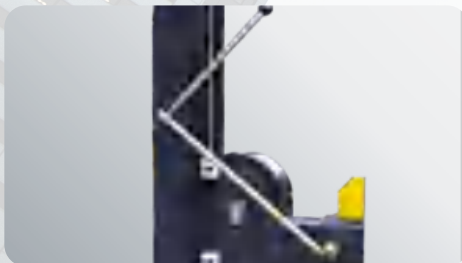

Hidden locking device and manual single-point safety lock release.



Optional caster kits help easily move the parking lift. Each 4-post parking lift needs 4 pieces (1 set).
Kits No.: 40801



EXCLUSIVE FEATURE

Double- shape column