

TRD

FOUR-POST **HEAVY-DUTY FOUR POST LIFT**

WITH GREAT PERFORMANCE, THIS IS THE PERFECT LIFT TO MEET THE NEEDS OF GARAGE AND SHOP OWNERS.



T034 TE034
T044 TE044

FOUR-POST LIFT

SPECIFICATIONS

PRODUCTS

| MODEL | | T0034 | TE034 | T044 | TE044 |
|------------------------------|---|---------|---------|---------|---------|
| Lifting capacity | | 13500kg | 13500kg | 18000kg | 18000kg |
| lifting time | | 116S | 116S | 160S | 160S |
| Overall Length (Inc. Ramps) | A | 7800mm | 9300mm | 9300mm | 10800mm |
| Overall Length (No Ramps) | B | 6514mm | 8014mm | 8014mm | 9514mm |
| Overall Width | C | 3794mm | 3794mm | 4100mm | 4100mm |
| Width Between Posts | D | 3348mm | 3348mm | 3654mm | 3654mm |
| Max.Lifting Height | E | 1900mm | 1900mm | 1900mm | 1900mm |
| Overall Height | F | 2332mm | 2332mm | 2332mm | 2332mm |
| Minimum Height | G | 265mm | 265mm | 265mm | 265mm |
| Max. Underneath Height | H | 1674mm | 1674mm | 1674mm | 1674mm |
| Drive-Thru Clearance | I | 2992mm | 2992mm | 3298mm | 3298mm |
| Width Between Runways | J | 1390mm | 1390mm | 1496mm | 1496mm |
| Outside Edge of Runways | K | 2610mm | 2610mm | 2916mm | 2916mm |
| Motor | | 4.0HP | 4.0HP | 4.0HP | 4.0HP |
| Gross Weight | | 2442kg | 3098kg | 3784kg | 4234kg |

FEATURES

PRODUCTS

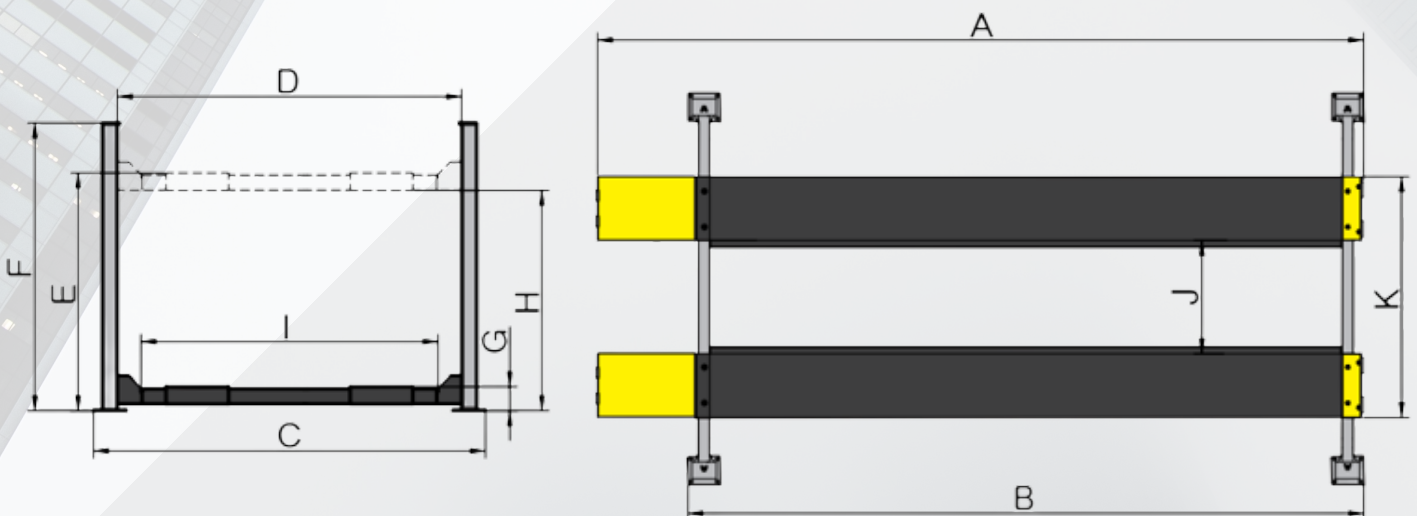

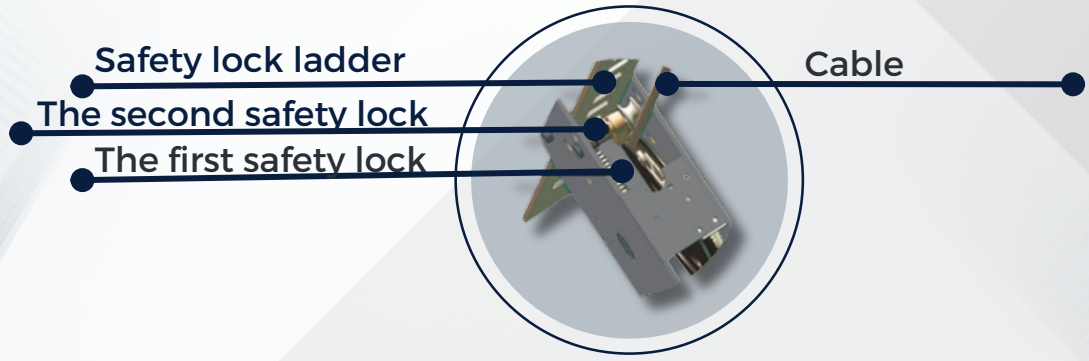
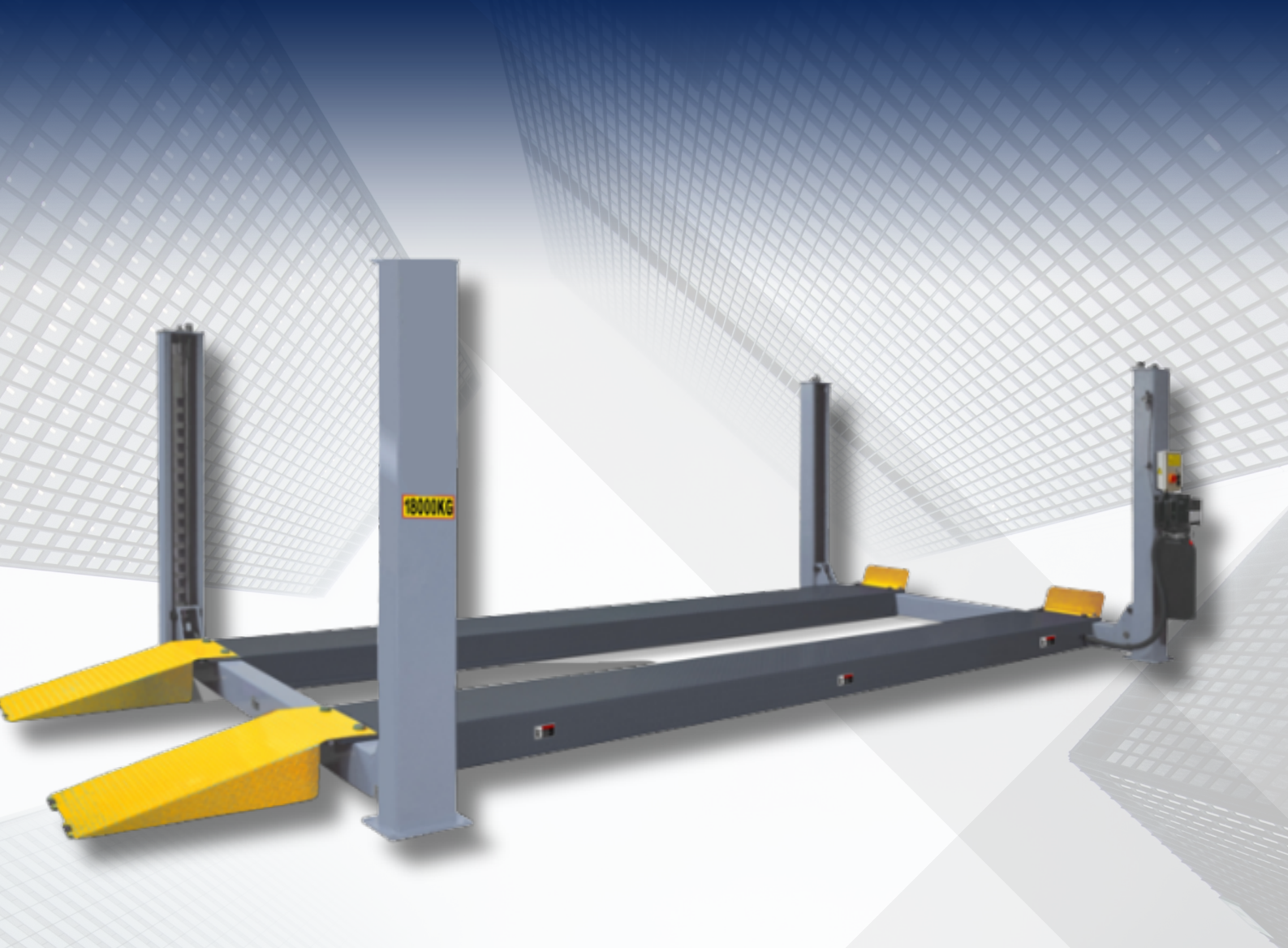

Optional airline kits. Easy to install with all models of rolling jacks with pneumatic pump. Kits No.:T60104

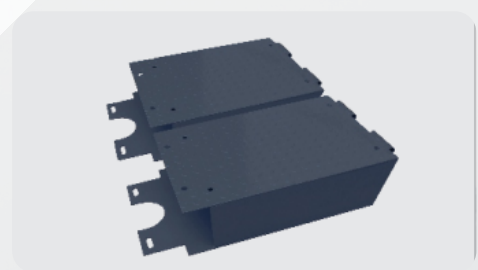

Optional platform extension kits add an extra 610mm (24") length to the platform. Kits No.:T10034



Optional LED lighting: 24V LED light. Kits No.:40104T4010.

FOUR-POST HEAVY-DUTY FOUR POST LIFT

TRD FOUR POST LIFT ARE MADE STRONGER, MORE VERSATILE, AND EASIER TO USE.

FEATURES

- Electric-air control operation system.
- Air-released safety lock for convenient operation and reliability. Mechanical self-locking device and cable-breaking protection. 3/4" aircraft quality synchronization cable.
- Skid proof diamond platform.
- Optional LED lighting: 24V LED light. Kits No.:40104
- Hydraulic cylinders are designed to high standards using high quality NOK seals. Strict quality control of cylinders with flow restrictors to keep a constant speed. Optional Rolling Jacks:
RJ-20A 15,000lbs capacity with pneumatic pump.



Electric control device With UP, LOCK and DOWN buttons
With C.E. stop switch at 300mm from ground and alarm tone when lowering down from 300mm to ground make the lift more safety



Optional Rolling Jack
RJ-20A pneumatic hydraulic type 9.0T



Oil-water separator and Solenoid air valve are installed on the power side column